

A2 INSTALLATION DRAWING

If this document is printed in hardcopy, it is for information use only and therefore is not subject to updating controls. Always refer to viewer for latest issue.

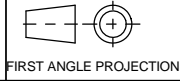

THIS DRAWING IS CONFIDENTIAL AND IS SUPPLIED ON THE EXPRESS CONDITION THAT IT SHALL NOT BE LOANED OR COPIED OR DISCLOSED TO ANY OTHER PERSON OR USED FOR ANY OTHER PURPOSE WITHOUT THE WRITTEN CONSENT OF AP RACING LTD.



AP Racing
Wheler Road
Coventry
CV3 4LB
Tel: +44 024 7663 9595
Fax: +44 024 7663 9599
e-mail: sales@ap racing.co.uk
Web site: http://www.ap racing.com

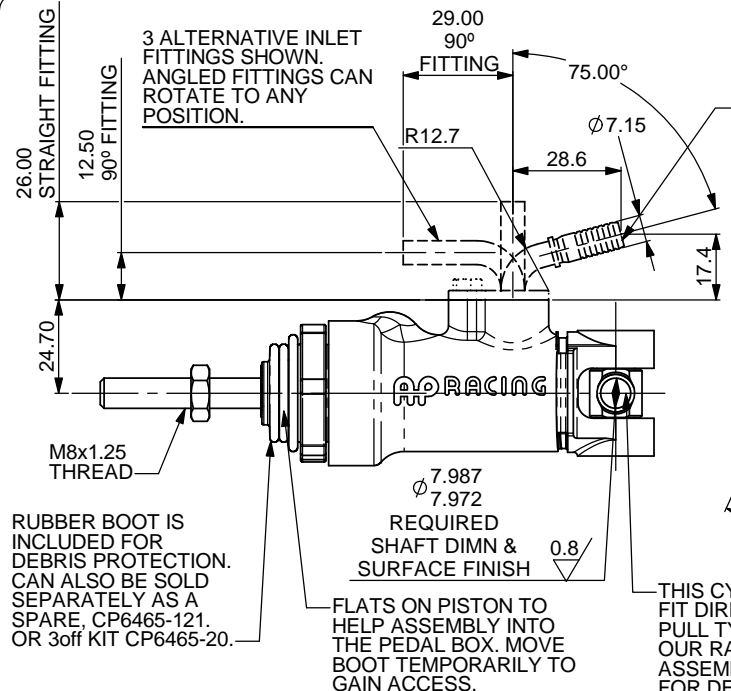

INLET FITTINGS SHOWN --- ARE NOT SUPPLIED WITH THE CYLINDER. THESE FITTINGS ARE DESIGNED TO SUIT THE GOODRIDGE G-LINE RANGE OF FITTINGS AND HOSES. AP RACING RECOMMENDS THE 910 SERIES HOSES.
ALTV. INLETS:- (AVAILABLE FROM AP RACING)
CP6465-10 (75° BEND AS SHOWN)
CP6465-11 (STRAIGHT)
CP6465-12 (90° BEND)

EACH PART WILL BE LASER ETCHED WITH THE SIZE, PART No. AND A SERIAL NO.

ISOMETRIC VIEW SCALE 3:4

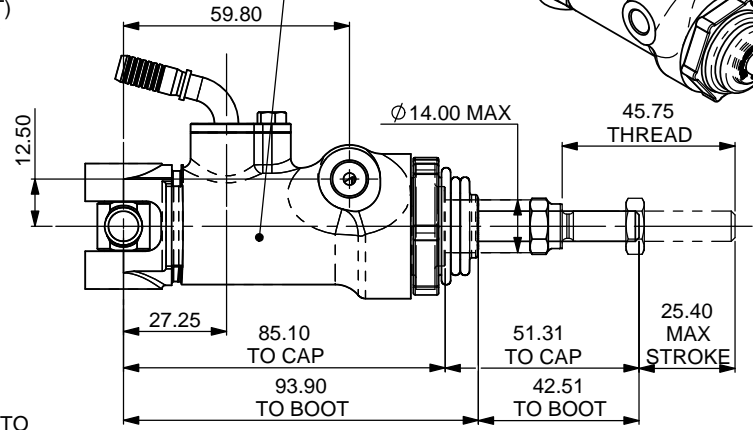
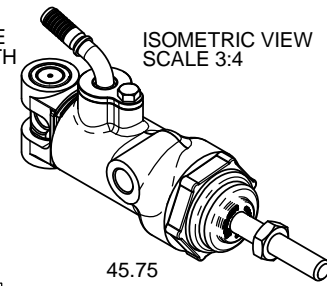

RUBBER BOOT IS INCLUDED FOR DEBRIS PROTECTION. CAN ALSO BE SOLD SEPARATELY AS A SPARE, CP6465-121. OR 3off KIT CP6465-20.

REQUIRED SHAFT DIMN & SURFACE FINISH

FLATS ON PISTON TO HELP ASSEMBLY INTO THE PEDAL BOX. MOVE BOOT TEMPORARILY TO GAIN ACCESS.

THIS CYLINDER IS DESIGNED TO FIT DIRECT TO OUR RANGE OF PULL TYPE PEDAL BOXES, AND OUR RANGE OF BALANCE BAR ASSEMBLIES. SEE CATALOGUE FOR DETAILS.

HEX HEAD BOLT M4x0.7 THREAD. RECOMMENDED TIGHTENING TORQUE 3.0 - 3.5Nm (2.2-2.5 lbf ft), WE ALSO RECOMMEND THE USE OF LOCTITE 243 THREAD LOCKER.

OUTLET M10x1.00 THREAD, 8.00 MIN THREAD DEPTH, SEE FITTING OPTIONS.

GENERAL DESCRIPTION

THIS PULL TYPE MASTER CYLINDER HAS BEEN DESIGNED TO BE MORE EFFICIENT THAN NORMAL MASTER CYLINDERS. THIS IS DUE TO THE COMPACT NATURE, THERE IS LESS CHANCE OF UNWANTED SIDE LOADING. DESIGNED INTO THE BACK OF THE CYLINDER IS NEEDLE ROLLER BEARING CLEVIS. THIS HAS BEEN DESIGNED TO FIT INTO OUR HIGH EFFICIENCY AND LOW HYSTERESIS BALANCE BAR. THE SPECIAL INLET FITTING AND 90Deg OUTLET ALLOWS THE CYLINDER TO SIT LOW BUT WITHOUT TRAPPING AIR. OUR SELECTION OF RECOMMEND OUTLETS ARE SHOWN ON SHEET 2. APPROX. WEIGHTS RANGE FROM 230grams TO 270grams.

FOR SEAL REPAIR KIT INFORMATION, SEE SHEET 2.

KIT INCLUDES ENOUGH PARTS FOR ONE CYLINDER, THOUGH IT DOES INCLUDE BOTH HANDED BRACKETS TO AID THE ATTACHMENT TO EITHER SIDE.

IMPORTANT NOTE

THE CP6465-254PRME MASTER CYLINDER HAS SOME DIFFERENCES WITH VARIOUS INSTALLATION DIMENSIONS, ARE ARE SHOWN BELOW.

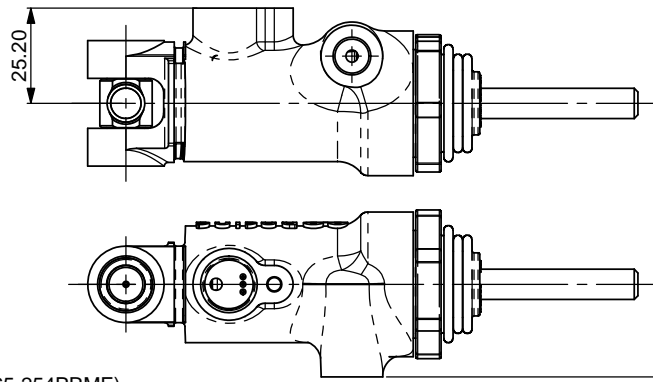

OPTIONAL POTENTIOMETER KIT CP6465-15, (SUITS ALL SIZES EXCEPT CP6465-254PRME)

PART NUMBER	CORRECTED BORE SIZES FOR CALCULATIONS	REFERENCE DIMS		
		BORE Ø (mm)	PISTON Ø (mm)	Area (mm²)
CP6465-149PRME	14,9 (0.587")	19.05	11.90	173.80
CP6465-162PRME	16,2 (0.638")	19.05	10.00	206.48
CP6465-173PRME	17,3 (0.681")	22.23	14.00	234.01
CP6465-188PRME	18,8 (0.740")	22.23	11.90	276.73
CP6465-202PRME	20,2 (0.795")	22.23	9.25	320.75
CP6465-212PRME	21,2 (0.835")	25.40	14.00	352.77
CP6465-218PRME	21,8 (0.858")	25.40	13.00	373.98
CP6465-224PRME	22,4 (0.882")	25.40	11.90	395.49
CP6465-237PRME	23,7 (0.933")	25.40	9.25	439.51
CP6465-254PRME	25,4 (1.000")	26.99	9.25	504.93

NOTE: OPTIMUM PULL TYPE CYLINDER DESIGN MEANS THAT TO USE STANDARDS SEAL SIZES AND BORE SIZES, THERE WOULD BE A SLIGHT VARIATION FROM STANDARD CYLINDERS. THE SIZES WERE ALSO ADJUSTED TO GIVE EQUAL STEPS BETWEEN THE DIFFERENT SIZES.

THE TABLE SHOWS THE MASTER CYLINDER PART NUMBERS AND A BORE SIZE THAT WOULD REFLECT A PUSH TYPE CYLINDER. THE CORRECTED BORE SIZE, THE PART NUMBER ALSO REFLECTS THE CYLINDER SIZE.

Issue No.	Alterations		Zone	Initials
	Date & No.	Particulars		
1	24/11/2003 B3160	FIRST ISSUE	#	CDA
2	24/11/2003	AREAS ADDED.	#	CDA
3	21/01/2004	WEIGHTS ADDED.	#	CDA
4	04/03/2004	STRAIGHT INLET FITTING CP6465-11 ADDED, FLATS ADDED TO PISTON.	#	CDA
5	27/07/2004	SHEET 2 ADDED, REPAIR KIT INSTRUCTIONS ADDED.	#	CDA
6	10/09/2004	CP6465-12 90deg INLET ADDED.	#	CDA
7	25/10/2004	RUBBER BOOT INFO ADDED.	#	CDA
8	28/10/2004	SPARES INFO ADDED, BALANCE BAR AND PEDAL BOX NOTE ADDED.	#	CDA
9	01/12/2004	CP6465-20 KIT NOTE ADDED.	#	CDA
10	02/03/2005	3 ALTV INLET CONNECTIONS AND RELEVANT DIMS ADDED, VARIOUS NOTES MOVED, ADDED OR MODIFIED TO CLARIFY.	#	DRA
11	22/05/2006 B4522	CP6465-254PRME CYL DETAILS ADDED.	#	CDA
12	03/03/2007 B4768	CP6465-15 POT KIT ADDED.	#	CDA
13	23/10/2008	M4 HEX HEAD BOLT TORQUE DETAIL ADDED.	#	CDA
14	08/05/09 B5588	CP6465-212 ASSY ADDED.		SAT
15	07/05/13 B6489	ITEM 5 SHEET 2 D-RING SEAL WAS O-RING SEAL	4G	SAT
16	23/07/15 B7359	ASSEMBLY CP6465-224PRME ADDED TO TABLE		SAT

SCALE 1:1	SHEET 1 OF 2
DRAWN	Chris Arrowsmith
APPROVED	
DERIVED FROM	
TITLE PULL TYPE MASTER CYLINDER	
DRG NO.	CP6465-1CD

A2 INSTALLATION DRAWING

If this document is printed in hardcopy, it is for information use only and therefore is not subject to updating controls. Always refer to viewer for latest issue.

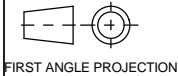

THIS DRAWING IS CONFIDENTIAL AND IS SUPPLIED ON THE EXPRESS CONDITION THAT IT SHALL NOT BE LOANED OR COPIED OR DISCLOSED TO ANY OTHER PERSON OR FOR ANY OTHER PURPOSE WITHOUT THE WRITTEN CONSENT OF AP RACING LTD.



AP Racing
Wheler Road
Coventry
CV3 4LB

Tel: +44 024 7663 9595
Fax: +44 024 7663 9559
e-mail: sales@apracings.co.uk
Web site: http://www.apracings.com

© AP Racing Ltd. 2005

REF	DESCRIPTION	INCLUDED WITH REPAIR KIT
1	PRIMARY CUP SEAL	Yes
2	SLYDRING BEARING	Yes
3	M/CYL RETURN SPRING	
4	PISTON WASHER	Yes
5	D-RING PISTON SEAL	Yes
6	PISTON STOP	
7	PISTON	
8	O-RING CAP SEAL	Yes
9	ENDCAP	
10	BODY	
11	LOCKNUT M8x1.25	
12	BOOT	

PART NUMBER	CORRECTED BORE SIZES FOR CALCULATIONS	REFERENCE DIMS			Repair Kits
		BORE Ø (mm)	PISTON Ø (mm)	Area (mm²)	
CP6465-149PRME	14,9 (0.587")	19.05	11.90	173.80	CP6465-149RK
CP6465-162PRME	16,2 (0.638")	19.05	10.00	206.48	CP6465-162RK
CP6465-173PRME	17,3 (0.681")	22.23	14.00	234.01	CP6465-173RK
CP6465-188PRME	18,8 (0.740")	22.23	11.90	276.73	CP6465-188RK
CP6465-202PRME	20,2 (0.795")	22.23	9.25	320.75	CP6465-202RK
CP6465-212PRME	21,2 (0.835")	25.40	14.00	352.77	CP6465-212RK
CP6465-218PRME	21,8 (0.858")	25.40	13.00	373.98	CP6465-218RK
CP6465-224PRME	22,4 (0.882")	25.40	11.90	395.49	CP6465-224RK
CP6465-237PRME	23,7 (0.933")	25.40	9.25	439.51	CP6465-237RK
CP6465-254PRME	25,4 (1.000")	26.99	9.25	504.93	CP6465-254RK

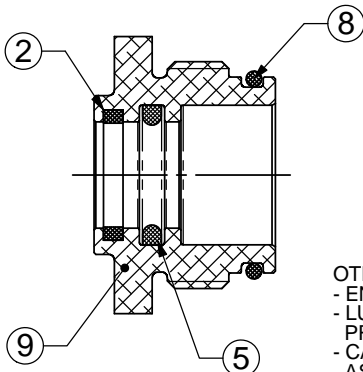

OTHER IMPORTANT NOTES:
 - ENSURE BORE IS FREE OF DEBRIS.
 - LUBRICATE SEALS AND BORE WITH BRAKE FLUID PRIOR TO ASSEMBLY.
 - CARE MUST BE TAKEN WHEN ASSEMBLING SEALS AS DAMAGE MAYBE CAUSED.

TIGHTEN ENDCAP TO 24Nm [18lbf-ft], AND USE LOCTITE THREADLOCKER, 242 or 243.

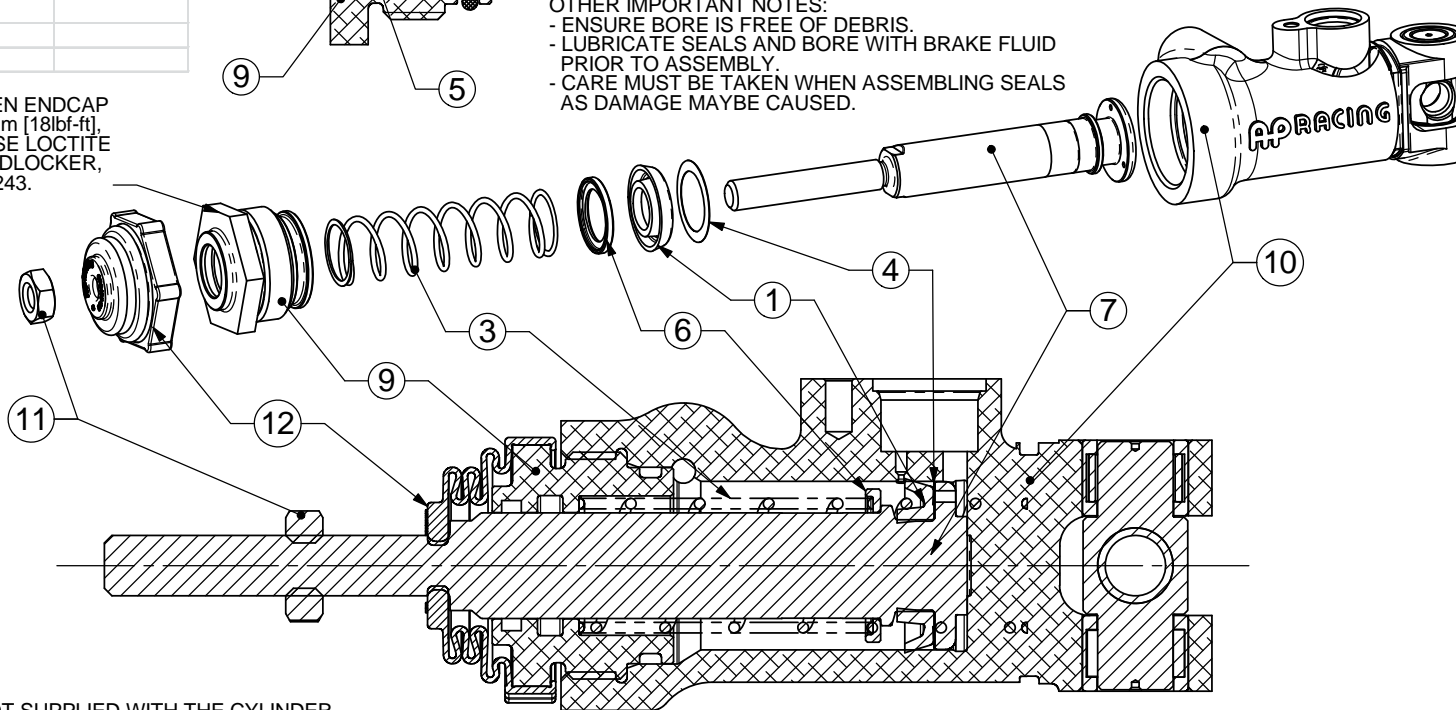

OUTLET FITTINGS NOT SUPPLIED WITH THE CYLINDER.
 ONLY OPTION B PARTS CAN BE OBTAINED FROM AP RACING.

OUTLET OPTION A

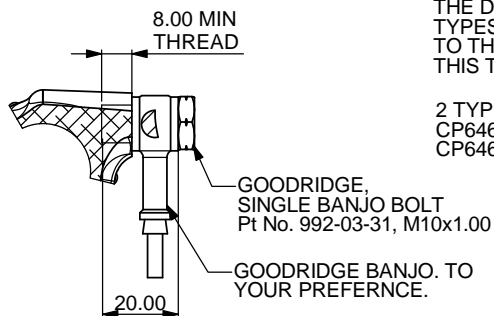

OUTLET OPTION B

THE DIFFERENT TYPES REFER TO THE THREAD ON THIS TUBE NUT.

2 TYPES:
 CP6465-16 - 3/8"UNF
 CP6465-17 - M10x1.0

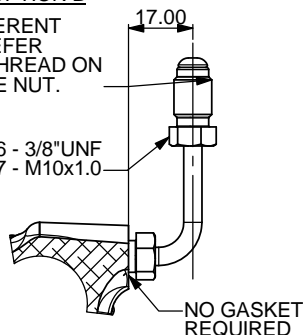

OUTLET OPTION C

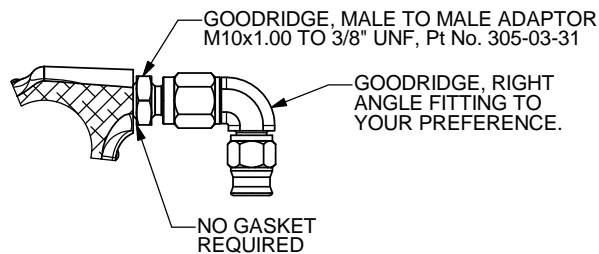

Issue No.	Date & No.	Alterations Particulars	Zone	Initials
		SEE SHEET1 FOR ISSUE LEVEL		

SCALE 1:1	SHEET 2 OF 2
DRAWN	Chris Arrowsmith
APPROVED	
DERIVED FROM	
TITLE PULL TYPE MASTER CYLINDER	
DRG NO.	CP6465-1CD